

SMART[®]
COMFORT

PRODUCT CARE & WARRANTY

LOUNGE RANGES





CONGRATULATIONS

Congratulations on the purchase of your new Smart Comfort Furniture. Please take time to read our care instructions and warranty information.

A clear vision, supported by a dynamic team, brings you furniture with enduring quality, design, comfort and style. Our uncompromising commitment and personality for customer care ensures that our products and services are the best available.

Smart Comfort develops high quality furniture, built to the needs of its customers. Our aim is to raise standards through innovation, quality materials and ensuring consistency throughout the manufacturing process. Our design team is highly experienced at combining world class design with carefully chosen materials and components that are tested to the highest standards.

We deliver comfort, strength and durability that you can depend on.



www.smartcomfort.com

QUALITY YOU CAN DEPEND ON

FRAME

A strong and durable foundation at the core

The frame is the foundation that your lounge suite is built on. Even though it's not visible, Smart Comfort ensures no corners are cut in order to deliver a frame that will last for years to come. We use solid pine and hardwood ply within the structural and load bearing areas. Corners are blocked, glued and screwed in order to provide maximum strength.

COMPONENTS

Quality componentry for peace of mind

We work with market leading suppliers to source the components that are used in your lounge suite. Whether it's electrics or mechanical, only tried and tested parts make the grade. All of the electrics used are tested to levels beyond the legal requirements to ensure your safety. We also specify a recliner mechanism that has a weight rating of 150kgs* and back it up with a 5 year warranty.

FABRIC

Ideal for all day, every day use

Our range of fabrics are handpicked to deliver style, durability and value for money. Each fabric is required to meet a strict performance criteria which includes tests for wearability, seam strength, resistance to pilling and colourfastness when exposed to light. This all combines to deliver a fabric you know will continue to look & feel great.

LEATHER

A luxurious and timeless look

We use a select grade of top grain corrected cow hide which makes it soft to the touch, durable and easy to maintain. All leather used is genuine. Like our fabrics, our leathers also go through a strict testing criteria to ensure their durability for every day life.

COMFORT

Sit back and put your feet up

At Smart Comfort we know that comfort is king. That's why careful consideration goes into our seat construction to ensure lasting comfort. High tensile zig zag springs are the first layer of comfort and deliver long lasting support. These springs work together to distribute weight evenly across the seat, crucial to the performance of the layers above. Next comes varying layers of foam. Denser foam at the base provides firmness and support for the seat and softer foam layers are added to deliver comfort levels second to none.

EXCEPTIONAL WARRANTY

OUR RIGOROUS QUALITY CONTROL ALLOWS SMART COMFORT
TO STAND BEHIND OUR PRODUCTS.



**STRUCTURAL
WARRANTY**



**FOAM
WARRANTY**



**MECHANICAL
WARRANTY**



**LEATHER
WARRANTY**



**ELECTRICAL
WARRANTY**



**FABRIC
WARRANTY**

WHAT TO EXPECT

**It's an exciting time unpacking your new lounge suite!
There are a few things you need to know.**

Smart Comfort products are upholstered with premium fabrics and soft, luxury leathers. We package them comprehensively to protect them during freight, but you may notice some minor creasing or crush marks in the upholstery upon opening. Rest assured that these will naturally work their way out with normal use.

Your suite needs time to 'break in', similar to a pair of shoes – it eventually molds and contours to your body shape. The seat and back cushion may initially feel firmer than what you experienced in the store as the foam in the floor model has been broken in with use- this is a normal function of foam.

You will find the foam will soften and then stabilise over time and use. This is not considered a warranty issue. If one seat is favoured over others it is not unusual to notice increased softness and wear and tear on this seat. It is recommended you alternate between seats for even wear.

With use, you may notice the leather or fabric upholstery appearing less taut on the surfaces. This is known as puddling and is a natural result of the upholstery stretching. It is not considered a warranty issue.



Smart Comfort sofas are designed to provide the most comfort and support when sitting in the middle of the seat cushion. Sitting off to the sides, front or back, will offer less support and may result in uneven wear and premature wear. **For the best comfort experience, please sit in the middle of the seat cushion:**

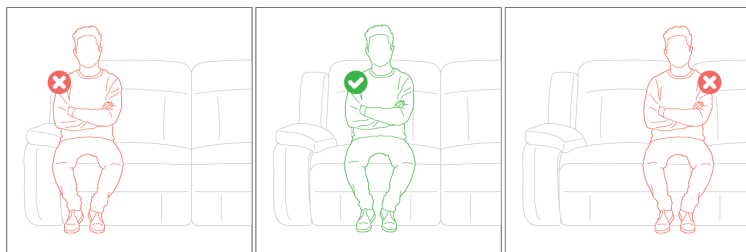

If your removable cushions include feathers, it is important to rotate and massage the cushions regularly to ensure they wear evenly and maintain their shape.

By looking after your lounge suite, it will continue to look and feel great. Follow the fabric and leather care guides in this booklet. Fluff and shape feather filled cushions to retain their comfort levels.

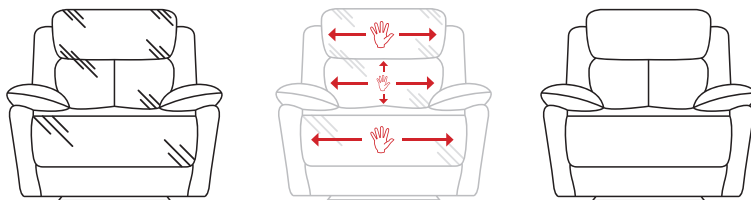

Smooth seat surfaces from the centre outwards to minimise the appearance of surface wrinkles.

LOOKING AFTER YOUR LEATHER

Our premium leather range has a luxury look and soft touch that sets our lounge suites apart from others. We specify a select grade of top grain corrected cow hide which makes it soft to the touch, durable and easy to maintain .

As a natural product, our leather shows the hallmarks of its previous life. Wrinkles, scars and slight imperfections should all be treated as signs of the leather's authenticity. No two hides are alike and nature's signatures on each piece ensure your Smart Comfort range furniture is unique.

Natural Characteristics of Leather



Blemish



Closed Scar



Neck Wrinkle

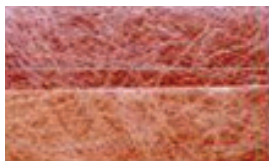

Shade Variance



Difference In Grain



Insect Bite

Corrected Top Grain

The Smart Comfort range uses corrected top grain leather as it offers the best of both worlds – softness and high durability. Top grain is the strong top layer from a hide when it is split. To ensure a more uniform finish, any excessive imperfections such as scars, insect bites and marks are corrected. This is done by lightly sanding the surface. A new grain pattern is then embossed in the leather to provide an overall even finish. A protective pigment is added making it ideal for the demands of everyday life.

Caring For Your Leather

Remember that leather is an animal hide, so you need to look after it like you would your own skin - clean and moisturise to ensure it stays soft and hydrated.

Under normal usage conditions, regular dusting and vacuum cleaning in crevices or bottoms is all that is necessary to clean your furniture.

The use of a good leather conditioner is recommended every 4-6 months.

Protect your furniture from the sun – especially direct light. Leather can fade to some degree if exposed to the sun.

For minor or slight scratches on the surface, use a chamois or clean finger to gently buff the scratch. If needed, moisturise lightly with distilled water to work scratches out.

For Spots and Spills

Blot excess liquid immediately with a clean, absorbent cloth or sponge. If necessary, use clean, lukewarm water and gently wipe the spill. Dry with a clean towel and allow to air dry. If water is used, clean the entire area where the spill occurred. For example, the entire seat cushion or entire arm. Do not dry wet areas with hair dryers, etc.

For Stubborn Spots and Spills

Use a mild solution of ivory soap and clean, lukewarm water. Apply the soap to a clean wet sponge and wash, then rinse well. Let air dry naturally. Always try the cleaning method in a hidden area first to convince yourself of the results. If the stain persists, it is recommended that the leather be cleaned by a professional leather specialist to avoid any potential damage to the leather.

For Butter, Oil or Grease

Wipe excess butter, oil or grease off the leather with a clean, dry cloth, then leave it alone as the spot should dissipate into the leather in a short period of time. Do not apply water to try to wash butter, oil or grease spot.

Do Not Use

Furniture polish, saddle soaps, oils, abrasive cleaners, soaps or varnish. The leather has been permanently preserved in the tanning process and needs no maintenance other than the simple cleaning recommended.

Note

Most liquids will be initially repelled by the leather, but, if left to stand over an extended period of time, they will be absorbed. That is why it is a good idea to mop up spills immediately. But even if the spill is absorbed, it will dissipate in time, just as human skin will absorb and eventually diffuse stains. Wipe surfaces weekly with a soft damp cloth to prevent the build-up of dust, body oils and dirt on the leather surface.

Maintain at least 2m distance between your furniture and heat sources.

Medications: If leather furniture is used constantly by individuals on some medications, (including, but not limited to; chemotherapy, blood pressure, diabetes and heart medications), extra care should be taken to protect leather surfaces from direct skin contact as the chemistry in these medications may react with and damage the leather finish. Headrest covers and arm protectors are advisable. Note these are not available as parts from the manufacturer so must be sourced elsewhere.

Be aware of sharp edges on clothing and accessories as these can cause damage to your furniture.

Keep pets off furniture. Claws can cause scratches and body oils from skin and fur can result in premature deterioration of the surface.

LOOKING AFTER YOUR FABRIC

Our quality fabric selection is tested for wearability, seam strength and colour fastness to light to ensure it will stand up to the rigours of everyday family use.

- Frequency of professional cleaning will depend on how regularly you use your furniture, your own maintenance routine, and environmental conditions. As a general guide, we recommend professionally cleaning your furniture every 12 months to maintain appearance and longevity of the fabric.
- If you do not regularly care for your fabric it may lose its appearance. Dirt, stains and odours will be harder to remove at routine maintenance and may become permanent.
- Some Smart Comfort fabrics feature a textured grain. With natural wear and tear, the grain can flatten and become less pronounced. This will be more noticeable on high traffic areas.
- Some Smart Comfort fabrics feature a fabric pile. Light reflects differently when the piles are facing in different directions giving the fabric a different colour. A uniform colour can be restored by wiping the piles all in the same direction.
- Vacuum clean regularly using low suction and a soft brush accessory.
- Clean spills and stains as soon as possible. Gently scrape any excess material off and mop liquid from the surface of the fabric. Do not scrub the area as this will create a noticeable difference in the texture of the fabric. Gently dab the spill taking care not to saturate the fabric or filling with water or cleaning fluid.
- Apply fabric cleaners strictly according to the instructions. Always test cleaners on an inconspicuous area before using. Refer to the fabric cleaning code on your furniture for more details on the fibre content.
- Slip covers and cushion covers are dryclean only.
- Fabric pilling can occasionally occur as a result of normal daily wear and should not be considered a fault. Pilling can be removed with a pilling tool, available from most homeware stores.
- Some Smart Comfort fabrics have a CO waterproof finishing. This finish creates an easy-to-clean fabric with a high level of stain resistance.
- Maintain at least 2m distance between your furniture and heat sources.
- Avoid placing your furniture in direct sunlight. All materials will fade over time from sustained exposure to direct sunlight.

- Be aware of sharp edges on clothing and accessories as these can damage your furniture.
- Keep pets off furniture. Claws can cause scratches and body oils from skin and fur can result in premature deterioration of the surface.
- If fabric furniture is used constantly by individuals on some medications, (including, but not limited to; chemotherapy, blood pressure, diabetes and heart medications), extra care should be taken to protect fabric surfaces from direct skin contact as the chemistry in these medications may react with and damage the fabric finish. Headrest covers and arm protectors are advisable. Note these are not available as parts from the manufacturer so must be sourced elsewhere.

ASSEMBLY

Assemble your Smart Comfort product in an open space with room to move. You may be required to rotate the product to attach feet and will need enough space to complete this action. Our products are generous in dimensions and weight, so we recommend utilising two people to assemble.

Unless sold as rearrangeable, products must be assembled in the configuration shown in the assembly instructions for warranty to apply.

Removing Base Timber Rails

Many of our 2 and 3 Seaters come with base timber rails to provide extra strength during freight. Please remove and dispose of the timber before using your product. Instructions and a removal tool are included on the timber rail.



Attaching The Back

1. Check you have selected the correct back for the seat base.
2. Align the Receivers (A) on the seat back with the Posts (B) on the base. Ensure both sides are aligned before pushing down firmly. The back will click into place.
3. Repeat across all seat backs. Console backs for 2 Seaters may be stored underneath the console.
4. If your product has a power headrest or power lumbar, connect the power cables between the seat back and base before velcroing down the back flap.

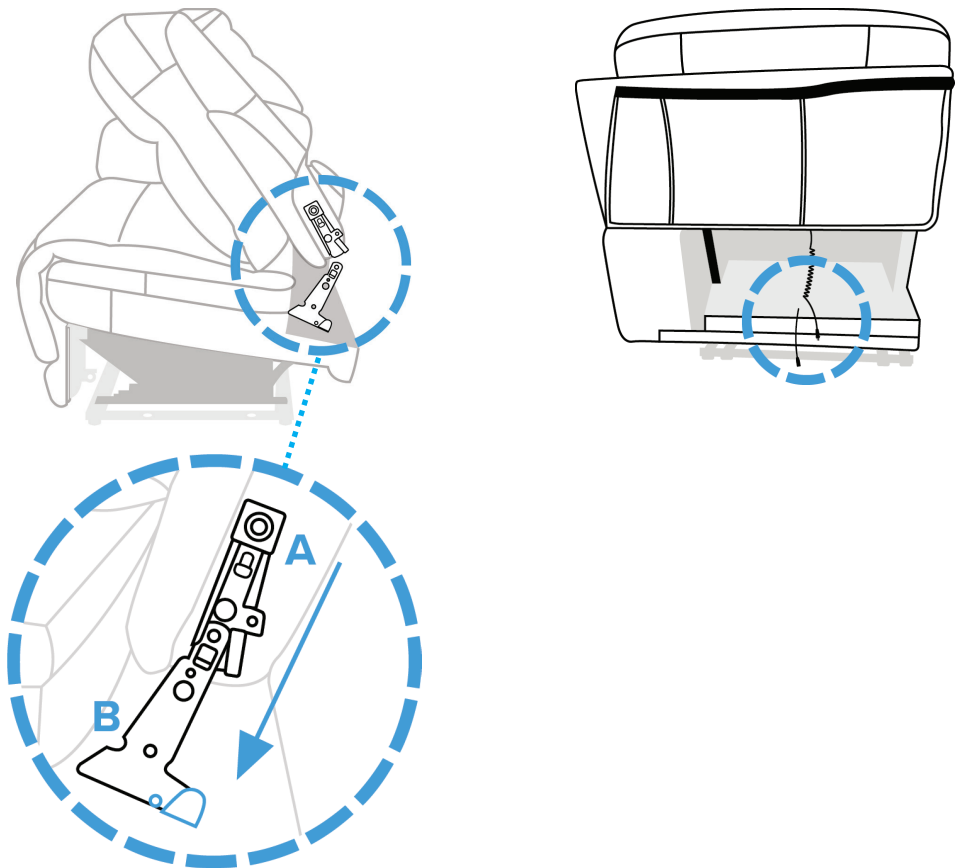



POWERING YOUR SUITE

Depending on the functionality included in your Smart Comfort lounge suite, there may be 1-4 power plugs to connect to fully power your product. Plugs and power supplies may be found tied to a seat post at the rear of the suite, tied to a base rail on the underside of the suite or in a storage compartment such as armrests or centre console. **Unless your suite is sold as being modular, it is important that you assemble suites in the configuration as purchased. If a suite is not assembled with pieces in the right order, it can cause alignment issues which aren't covered under warranty.**

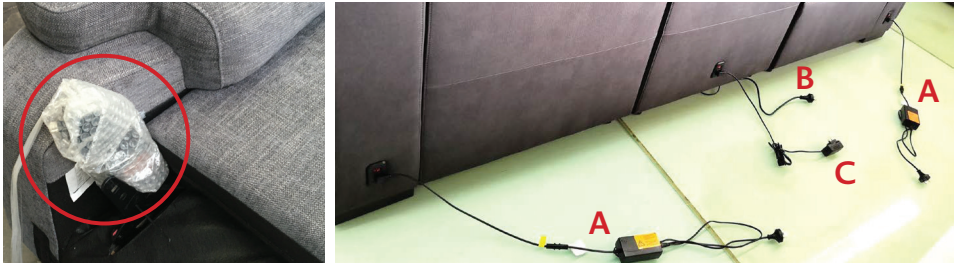

Power Recline/Power Lumbar/Power Headrest

Power for these functions is typically located in the rear of the armrests of your suite (A).

There may be 1 or 2 connections required depending on the functionality of your lounge suite. As mentioned in the Attaching the Backs section of this booklet, ensure the power cables between the seat base and the back are connected for the power headrest and/or power lumbar. Ensure the brackets connecting each piece are connected before connecting the wires. To prevent damage when moving your furniture, disconnect wires.

Wireless Charging Pad

If your product has a wireless charging pad, the power plug (B) for this is located at the rear of the piece containing the charging pad.

Reading Lights

If your product includes reading lights, the power plug (C) for these is located at the rear of the piece containing the reading lights.

TROUBLESHOOTING

If you are having any issues, please try the following solutions.

- Check that all plugs are plugged into a wall outlet and are secure. Please check that the wall outlet is switched on. Confirm power is going to your suite by checking the green light is showing on the suite power box. Check that all switches at the rear of the suite are switched on.
- Check to ensure that all connection cords are properly connected, as per the instructions in this booklet. There are multiple connections, any of which being too loose may cause performance issues.
- Ensure no cords are pulled too tight. If the cord does not reach its destination with ease you may be trying to plug it into the wrong location. Please refer to the instructions. If it is still too short/tight, please contact the store you purchased the suite from.
- Try plugging the suite into a different wall outlet.
- The USB ports included in our products are low voltage. Please use the 240V socket in the charge station, if your product includes one, if you are charging a larger device or require a faster charge.
- Unplug the suite from the wall for 5 minutes to reset all electrical components.
- Ensure there is nothing obstructing the recliner movement.

Please check all connections before contacting the store for help.



WARNINGS

- Ensure there is no person, animal or item obstructing the area under the footrest before operating this product.
- Improper use or installation may result in the risk of fire, electric shock and/or injury. We assume no liability for any eventual damages caused by improper use or inappropriate handling, or by any other non-compliance with the instructions in this manual.
- This product is not intended for use by persons (including children) with reduced physical, sensory or mental capabilities, or lack of experience and knowledge, unless they have been given supervision or instruction concerning use of the product by a person responsible for their safety.
- Children should be supervised to ensure that they do not play with the appliance.
- Keep fingers, hair and body parts well clear from moving parts. To reduce the risk of injury, keep children and pets clear of the product when in use.
- Do not sit or place additional weight on the arms, back or open footrest. Damage caused as a result of excessive force is not covered under warranty.
- This product is very heavy. Only move this product by lifting the main body. Never drag by the footrest, back or arm rest.
- Return this product to the full upright position to stand safely and prevent a tripping hazard.
- Do not operate this product if damage is visible in any form.
- Do not modify or use unauthorised substitute parts.
- This product has been designed and intended for indoor residential use only.
- This product is not suitable for commercial or outdoor use.
- This product is not intended to be used as part of a health care plan. Consult your medical professional before operating if you are taking medication or have physical limitations.
- Never force the back or footrest to close faster than the electric motor.
- Before commencing cleaning or maintenance, ensure this product is disconnected from the power outlet and the back is in the full upright position.
- Disconnect this product from the power outlet before moving.
- Cease operation and disconnect from the power outlet if you ever detect a burning odour or smoke coming from the product.

- Do not operate this product if liquid spillage occurs on or around it.
- Disconnect from the power outlet and allow product to completely dry before reconnecting.
- Do not operate the power functions or charge station with wet hands.
- Check the condition of the power cord, electrical cords, transformer, plug and connector on a monthly basis. Do not operate if wear is visible.
- Ensure the power cord, electrical cords and transformer are clear of moving parts and not trapped underneath the base.
- Position the power cord to minimise a tripping hazard.
- Never attempt to open or disassemble electrical components.
- We recommend the use of a surge protector (not included).
- If recliners are placed on hard floors, there is a possibility the mechanism could scratch the floor and any such damage is not covered under warranty. It is recommended you place the recliner on a non-stick mat in this instance. Should an issue arise with the recliner mechanism, do not use the reclining function until it has been repaired

WARRANTY

Any warranty claims should be directed to the retailer where you purchased your furniture. ALL warranties detailed in this booklet:

- Only apply to furniture used for domestic purposes and only while the furniture and parts are cared for and cleaned in accordance with the instructions in this booklet and attached to your Smart Comfort product.
- Do not extend to cover furniture which, in the opinion of Smart Comfort, is worn by normal wear and tear, or has been damaged or rendered defective through misuse, abuse and negligence. If a furniture assessment identifies that damage is not a result of a manufacturing fault, Smart Comfort reserves the right to charge for the assessment.
- Are issued only to the original purchaser or beneficiary.
- Extend only within country of purchase
- Smart Comfort will bear the reasonable expenses of claiming the warranty, if in fact it is a warranty issue. Smart Comfort reserves the right at all times to approve transportation charges prior to them being incurred.
- Replacement of product or parts does not extend or restart the warranty period.
- To receive the benefits of this warranty you must retain proof of purchase, which must clearly show the purchase date as this marks commencement of warranty periods. **Please contact the retailer dealer from whom you made your purchase.**
- Warranty claims must be reported in a timely manner. Additional damage resulting from delayed reporting or continued use is not covered by warranty.



**STRUCTURAL
WARRANTY**

Take care not to sit on arms or apply excessive weights to frames. A frame or seat suspension system damaged as a result of force is not deemed warranty. Smart Comfort will, within 5 years of the original sale of this product, repair or replace, at its option, any part of the frame construction and seat suspension system which it deems to be defective in workmanship or materials. Structural warranty does not include leather, fabric or recliner mechanisms.



**FOAM
WARRANTY**

Foam will always soften with use. Areas of greater use are likely to soften earlier than unused areas. As a result, the upholstery cover may show visible signs of being less taut, also known as “puddling”. The seat cushion foam and filling materials are warranted against defective material or workmanship for a period of 5 years from the date of the original purchase.



**MECHANICAL
WARRANTY**

Mechanical specifically covers the metal recliner mechanism. It does not cover the motors or electrical systems which drive it or recliner triggers and cables on manual systems. Smart Comfort will, within 5 years of the original sale of the product, repair or replace, at its option, the recliner mechanism which it deems to be defective in workmanship or materials. Recliner mechanisms are not intended to support weights over 150 kilograms unless otherwise stated. Examples of mechanical issues could include grinding, rough mechanical movement or jamming.



**FABRIC
WARRANTY**

Smart Comfort will, within 1 year of the original sale of the product, repair or replace, at its option, any fabric or vinyl which is found to be faulty as a result of the manufacturing process.



**LEATHER
WARRANTY**

The natural beauty of leather means that no two pieces of leather are exactly alike. As such, natural markings and grain variations are not considered defects. Smart Comfort will, within 3 years of the original sale of a leather covered product, repair or replace, at its option, the leather covering if it is subject to technical faults from the tanning process that result in abnormal or unusual wear, or unusual colour changes.

A SPECIAL NOTE ON LEATHER AND FABRICS:

The leather/fabric warranties in this booklet do not apply where there is evidence of excessive soiling, improper cleaning, abuse, or where the leather/fabric has had a chemical treatment applied by the retail dealer or consumer, which has not previously been approved in writing by Smart Comfort. Please do not move furniture by pulling on leather or fabric.

Medications: If leather/fabric furniture is used constantly by individuals on some medications, (including, but not limited to; chemotherapy, blood pressure, diabetes and heart medications), extra care should be taken to protect leather/fabric surfaces from direct skin contact as the chemistry in these medications may react with and damage the leather/fabric finish. Headrest covers and arm protectors are advisable.



ELECTRICAL WARRANTY

Smart Comfort will, within 2 years of the original sale, repair or replace, at its option, electrical components if it is subject to technical faults that result in the action no longer working. Please do not place excess length of electrical cable under the recliner. Wires may get caught in moving parts and result in a short circuit in the electrical system.

ALL OTHER PARTS - 1 YEAR

All other parts not specifically warranted have a 1 year warranty against defective materials or workmanship. This includes parachute and recliner triggers and cables. Smart Comfort will bear the reasonable expenses of claiming the warranty, if in fact it is a warranty issue.

Replacement parts are available to be purchased from the retailer where you purchased your furniture for non-warranty or out of warranty repairs. Replacement parts will have a 12 month statutory warranty.

Smart Comfort guarantee that the product will be free from defects in workmanship and materials.

Our goods come with guarantees that cannot be excluded under consumer law, from within the jurisdiction you purchased the product.

The warranty set out in these terms and conditions is provided by:

Smart Comfort Limited

483 Green Lanes
London
N13 4BS
United Kingdom

SMART[®]
COMFORT

www.smartcomfort.com



